



# Panel Fan Series

# Manual-2026

(Installation, Operation, Warranty)

*Shanghai Terrui*

202603A

**Thank you for choosing Shanghai Terrui products!**

**We are deeply honored by your trust, and this recognition drives us to uphold the highest standards of quality and service in every aspect of our operations.**

**Terrui's quality policy is the cornerstone of our development and the guideline for every team member:**

**Actively listening to customer needs means we go beyond order-taking to understand your actual application scenarios, functional requirements, and after-sales expectations, integrating your feedback into product design and service optimization.**

**Carefully building product quality involves strict control over every link—from raw material selection to final inspection—following international and domestic industry standards to ensure reliable, stable products.**

**Sincerely providing satisfactory service means our after-sales team stands ready to address technical consultations, installation guidance, and maintenance needs promptly and efficiently. Most importantly, we never forget that customer satisfaction is the core of our survival and growth.**

**Read this manual carefully before installing or using the equipment!**

**This manual includes critical information on product structure, installation steps, operation procedures, safety precautions, and troubleshooting. Correct installation and standardized operation are essential to maximizing product performance, ensuring user safety, and extending equipment service life. Unauthorized operation without referring to the manual may lead to equipment malfunctions, performance issues, or even safety hazards.**

**We look forward to delivering reliable products and services that meet your expectations.**

# INDEX

<b>1</b>	<b><i>Products basic information</i></b>	<b><i>1-4</i></b>
<b>2</b>	<b><i>Products basic information</i></b>	<b><i>5-8</i></b>
<b>3</b>	<b><i>Repair and maintenance</i></b>	<b><i>9-9</i></b>
<b>4</b>	<b><i>Wires Connection Diagram</i></b>	<b><i>10-16</i></b>
<b>5</b>	<b><i>Quality assurance policy</i></b>	<b><i>17-17</i></b>

## Product basic information

### 1. Product description

Panel fan series, is a large air volume, effectively achieve environmental cooling direct transmission large fan. The fan adopts a more energy-saving and efficient permanent magnet brushless motor, which improves the overall efficiency of 30% compared with the ordinary direct connection fan. Panel fan series not only has large air volume, strong wind speed, low noise and low energy consumption, but also can be used with spray system and frequency conversion and temperature control system at the same time. The Panel fan is made of anti-resistant materials, which is installed on the fan support, which is strong and durable. With high performance and reliable quality, it effectively solves the cooling problem of use scenarios.

### 2. Safety note description

Panel fan is a ventilation equipment specially developed and designed for dairy farming. However, if it is not operated and used correctly, it will cause a dangerous situation. Therefore, please strictly follow the following safety instructions:

- (1) Children and non-professionals should stay away from the installation site.

The blades may cause damage to their fingers and other parts of the body.

- (2) Please check the fan use manual carefully before installation. Users who use the drive and temperature controller, also need to check the drive and controller instructions.

- (3) When operating the fan, drive and controller, safety precautions:

- ① Equipment testing before installation:

When the equipment component is missing or damaged parts, please do not install, forced installation will cause damage to the equipment.

- ② When installing:

The fan installation belongs to the high-altitude work, please do the safety protection work of the installation personnel.

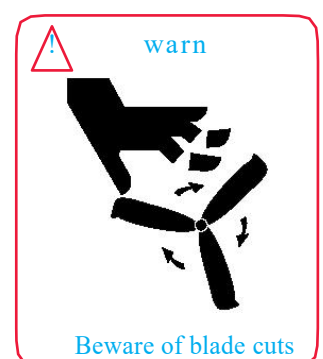

③ When wiring:

- ✧ The instructions of this manual must be followed and installed by professional electrical engineers, otherwise an unexpected danger will occur!
- ✧ Make sure the power supply is powered off before wiring, otherwise there is a risk of electric shock!
- ✧ Please properly ground according to the standard lead line, otherwise there is a danger of electric shock!
- ✧ Communication line (sensor or gateway to dedicated drive 485 communication line) must use the shield line.

Before the power:

- ✧ Note to check for the presence of a short circuit in the peripheral circuit connected to the electrical equipment; whether the connected circuit is fastened. Otherwise, the fan will be damaged!
- ✧ The sensor or gateway must be connected before it turns on. Otherwise, it may cause an electric shock!
- ✧ Adjust the parameters of the drive and the controller according to the operating instructions.
- ✧ Do not contact the fan with any part of the body.
- ✧ Do not repair and maintain the equipment with live equipment. Otherwise, there is a danger of electric shock!
- ✧ When maintaining and maintaining the fan, it must be operated after the power off for 2 minutes, otherwise the residual charge on the capacitor will cause harm to people!
- ✧ Personnel without professional training should not repair and maintain the fan and control unit, otherwise it will cause personal injury or equipment damage!
- ✧

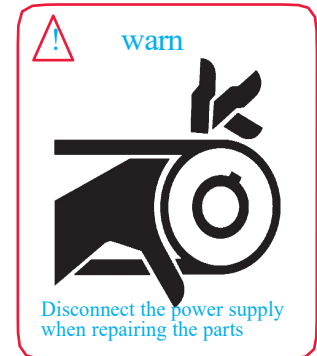

### 3. Product features

- ◆ Corrosion-resistant, high-strength polyethylene housing.(45, 63, 78, 86" and 98 is fiberglass)
- ◆ Adopt energy-saving and efficient permanent magnet brushless motor.
- ◆ All alloy fan blades to ensure the strength of the fan blades while providing strong and uniform air flow.
- ◆ Maintaining the lowest speed in winter can enhance the air circulation in the house,

effectively reduce the air

humidity, contribute to the balanced distribution of heat in the barn, and maintain the optimal environmental temperature and humidity in the barn.

#### 4. Technical parameters

Name	Power supply	Air volume	Power	Current	RPM	Install
38" Panel fan	3Φ,380-460V,50/60Hz	27000m <sup>3</sup> /h	300W	0.8A	750r/min	60mm round pipe
45" Panel fan	3Φ,380-460V,50/60Hz	35000m <sup>3</sup> /h	500W	1.1A	610r/min	
48" Panel fan	3Φ,380-460V,50/60Hz	48000m <sup>3</sup> /h	1050W	2.3A	505r/min	
55" Panel fan	3Φ,380-460V,50/60Hz	66000m <sup>3</sup> /h	1200W	2.4A	460r/min	
63" Panel fan	3Φ,380-460V,50/60Hz	90000m <sup>3</sup> /h	1700W	3.5A	444r/min	
72" Panel fan	3Φ,380-460V,50/60Hz	120000m <sup>3</sup> /h	2000W	3.5A	345r/min	60-70mm round pipe
78" Panel fan	3Φ,380-460V,50/60Hz	135000m <sup>3</sup> /h	2400W	3.7A	310r/min	
86" Panel fan	3Φ,380-460V,50/60Hz	155000m <sup>3</sup> /h	3300W	5.9A	320r/min	
98" Panel fan	3Φ,380-460V,50/60Hz	230000m <sup>3</sup> /h	5200W	9.1A	305r/min	
114" Panel fan	3Φ,380-460V,50/60Hz	300000m <sup>3</sup> /h	7500W	13.5A	285r/min	
6 quality testing procedures ① motor balance testing ② noise detection ③ vibration and rotation concentric perform testing ④ blade speed detection⑤ Air volume detection ⑥ overall efficiency detection						

(Above data is obtained from the factory laboratory)

## 5. Installation requirements

### **Before installation, consider the following:**

- ✓ The fan should be installed in the indoor environment, do not expose the fan to rain, snow and harsh environment.
- ✓ It is strictly prohibited to place the equipment in the flammable and explosive gas.
- ✓ Lifting and lifting equipment shall avoid equipment falling or damage.
- ✓ The installation position must be correct, and no additional load can be added to the equipment.
- ✓ Installation and maintenance of electrical parts must be carried out by professional (qualified) personnel and inspected regularly.
- ✓ The three-phase power on the site must be stable, the power is unstable or phase deficiency, easy to burn the motor.
- ✓ Check that the base mount is firmly secured.
- ✓ Check whether the wiring mode is correct.
- ✓ Check whether the power supply system and power parameters completely match the fan nameplate.
- ✓ Ensure that the fan rotates smoothly without jamming, abnormal sound and other faults.
- ✓ Check whether the motor vibration is too large, and whether there is any abnormal phenomenon such as overall shaking and shaking.
- ✓ Check to ensure that there are no screws and other solid foreign bodies to be sucked into the fan.
- ✓ Within 15m from the RF equipment (e. g., milking machine, ear identification, collar identification, etc.), and the input power cord must be shielded and fixed with metal sleeve or card slot.

# Installation instructions

## 1. Main component composition

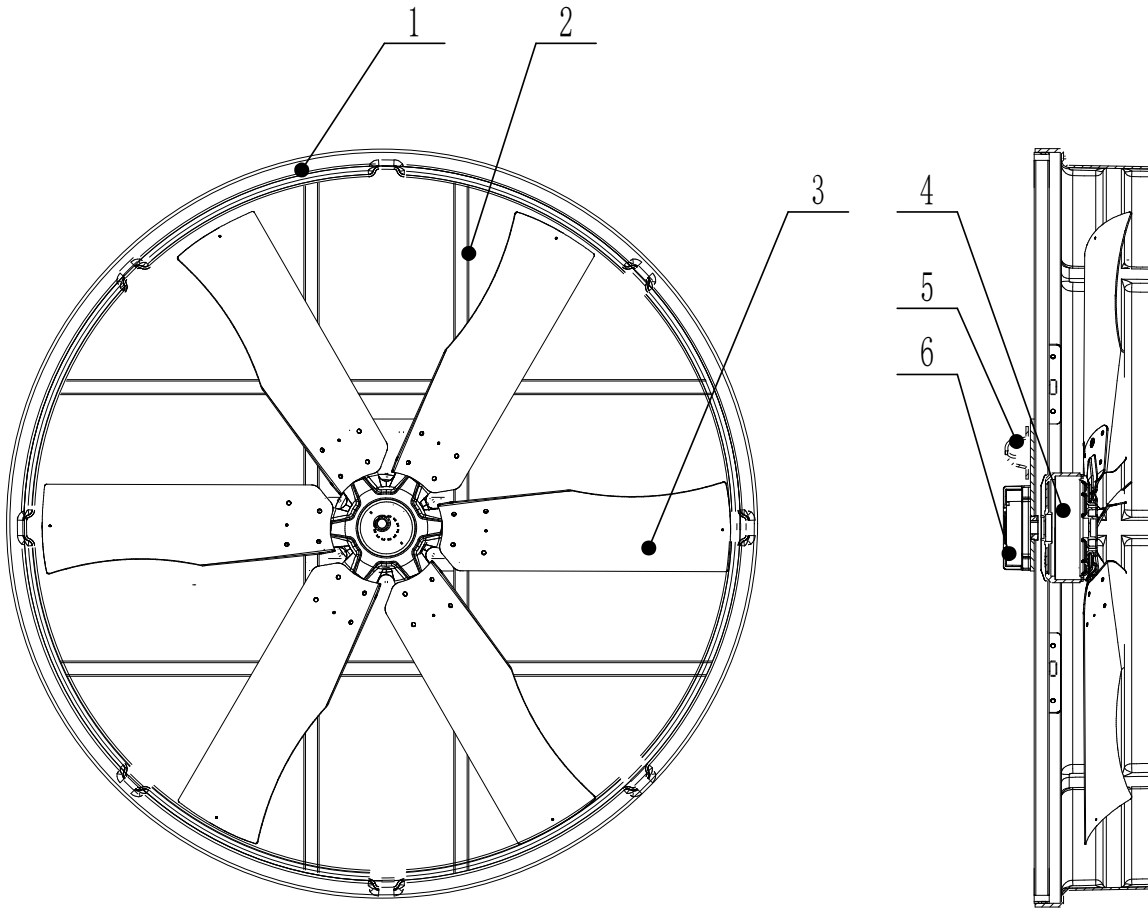

Figure 1

Figure 2

NO	Part Name	Quantity
1	High strength housing	1
2	Fan support H bracket	1
3	High-strength aluminum alloy fan blade	6
4	EC permanent magnet synchronous motor	1
5	Fan round tube hoop (72" below 60mm hoop, 72" and above 70mm hoop)	1
6	Programmed drive (including IOT function)	1

## 2. Fan operating instructions

The operation of the fan is divided into the following two types according to the control mode: (★ The Internet of Things gateway and temperature sensor are optional, and need to be purchased separately)

1. Without the temp sensor and Internet of Things gateway, after power up, the fan starts and gradually increases the speed until full speed rotation; when stopped, it is opposite to start.
2. There are Internet of things gateway, temp sensor or other speed controller, receive different output signals of the controller, the fan automatically adjust the output signal, so as to achieve the purpose of controlling the speed of the fan according to the ambient temperature. In addition, those connected to the Internet of Things and the gateway can directly close the fan manually through the mobile APP.

## 3. Fan installation instructions

According to the fan model in the fan parameter table, select the round pipe with a wall thickness of more than 3mm. The two ends of the round pipe are bent to ensure the middle length of the length of the whole Panel fan hoop. Fixed the two ends of the bend and the top beam on the round pipe with accessories (Figure 3). The method of fixing or welding the tube can be arranged according to the actual conditions of the farm roof environment. Ultimately, a horizontal tube parallel to the clamp direction is needed to support the fan. Additional installation shall meet the following requirements:

- a) Ensure the installation height, and the recommended installation height is in 3m~3.5m.
- b) Ensure the appropriate installation distance (Figure 4, Figure 5). On a ranch, the spacing can be adjusted according to the specific barn environment. Typically, for fans 63 inches and below, installation every 6 meters per unit works best; for fans 72 inches and above, installation every 12 meters per unit delivers optimal performance.
- c) Ensure that the tilt angle of the fan is between 30 ° and 45 °.

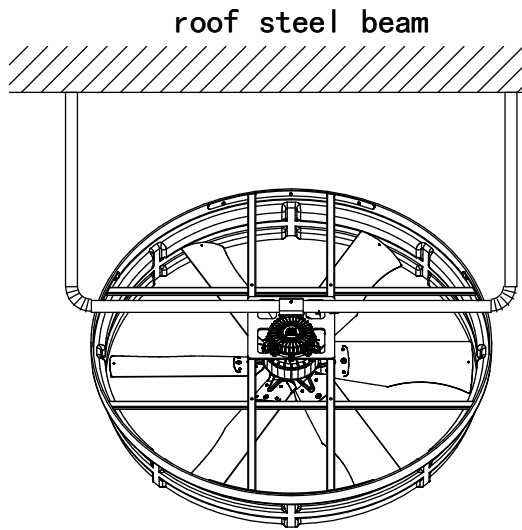

Figure 3

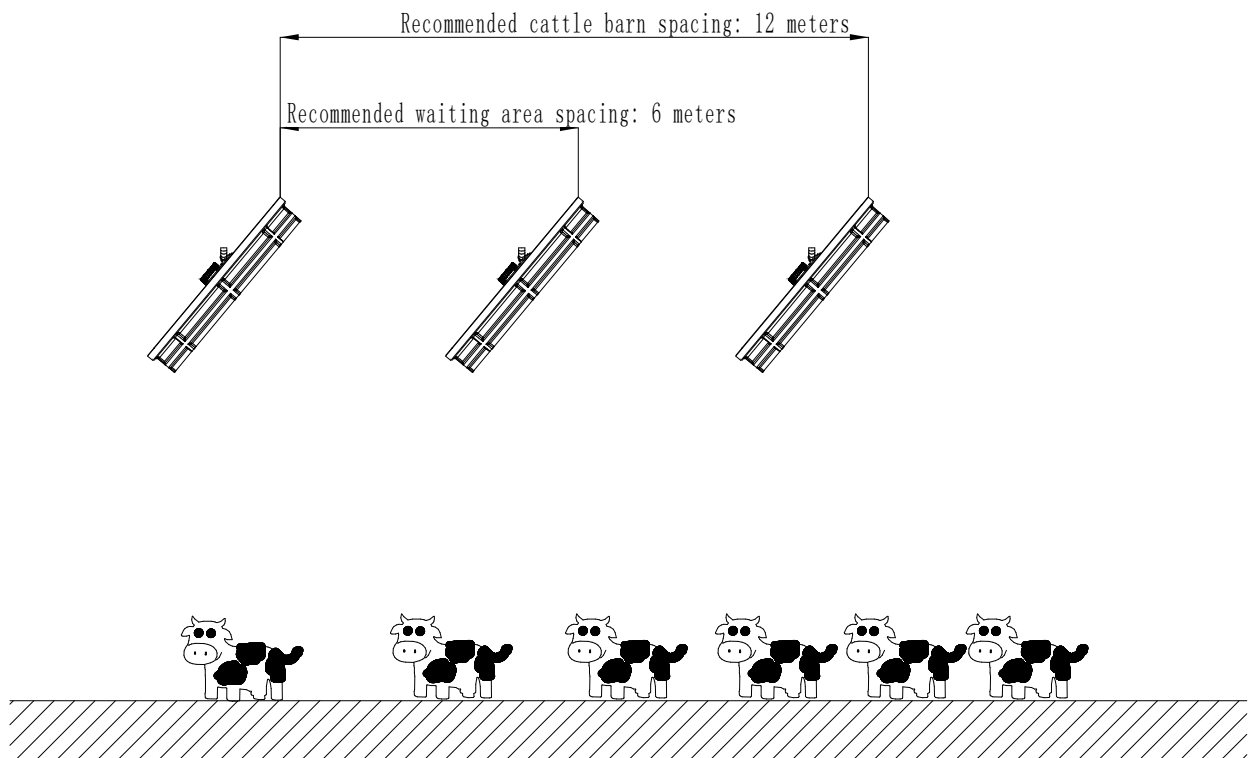

Figure 4

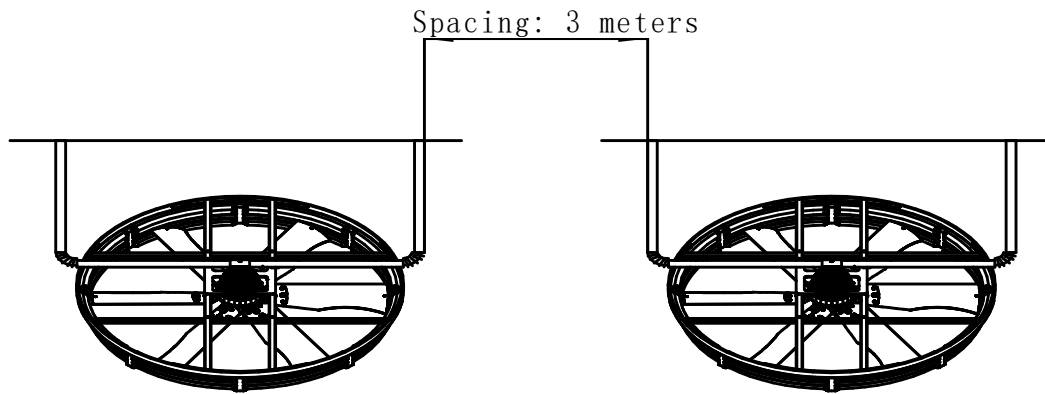

Figure 5

#### 4. Fan debugging (★ Internet of Things gateway and temp sensor are optional, need to be purchased separately)

1. Power up the fan, observe whether the fan operates according to the drive setting procedure, whether the fan running state is stable, whether there is abnormal sound, and whether the fan blade turning is correct. If there is a problem, it should be adjusted in time. After the problem is completely handled, put it into normal use.
2. There is the Internet of things and the temperature sensor, where the output signal of the temperature controller controls the startup and the output frequency of the drive, so as to achieve the purpose of controlling the speed of the fan according to the ambient temperature. Check whether the speed of the fan has also increased after the increase of the temperature in the barn.

#### 5. Note for fan transportation, installation and commissioning

1. The fan must be stored indoors, and must be placed according to the upward mark on the fan, the fan puts the fan at most one layer, and the fan is forbidden to fall to the ground (if it is forbidden to contact the motor to the ground, it is easy to deform).
2. In the process of placing, moving, installation and contact of the fan, we must ensure that the blade of the fan is not affected by external force to avoid blade deformation and damage.
3. The grounding wire of the power cord arranged in the barn must be firmly connected to the ground wire of the lead line of the fan, and often check whether the grounding wire of the power supply is well connected.
4. Before the fan is energized, the control switch of all fans must be turned off, and the debugging must be one fan opened, one adjusted, one opened, one completed and one closed.

## Repair and maintenance

### **Special attention!**

Before any maintenance and maintenance of the fan, be sure to disconnect the power supply to ensure the safety of relevant operators, otherwise it may cause a serious threat to life safety. The maintenance work of the equipment must be carried out by the professionally trained personnel!

- ✓ Clean the dust on the fan regularly and brush the dust on the fan leaves. Too much dust may lead to the shaking of the fan and affect the service life of the fan. Note: When cleaning and maintaining the fan, spray the fan bearing or fan motor.
- ✓
- ✓ Keep the capacity of the power supply facilities sufficient, the voltage is stable, and it is strictly prohibited to run in phase absence. The power supply lines must be special lines, and temporary lines are not allowed to use power supply.

## Wires Connection Diagram

Terrui fan lead-out lines:

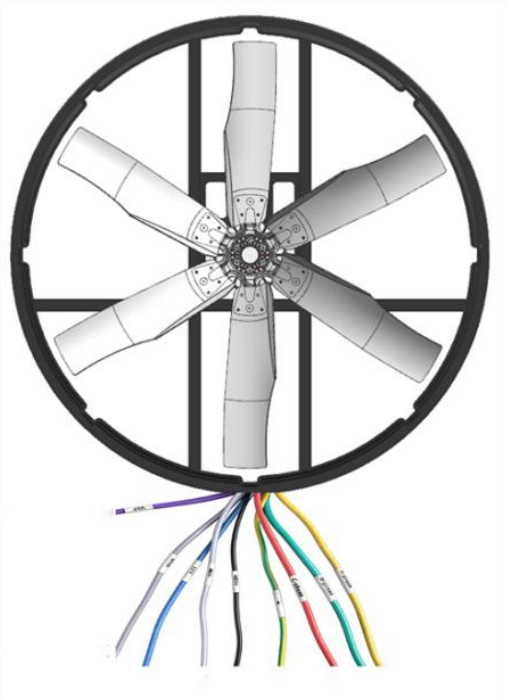

Terrui fan standard models typically feature 9 lead-out wires, with their functions specified in the table below. Before wiring, verify the wiring diagram and confirm model variations with us.

Cables/Color	Function declaration	Attention
A/B/C (Yellow/Green/Red)	Three-phase power live wire	Connection is required, and the voltage must match the fan's nameplate.
PE ( olivine )	grounding conductor	Ensure reliable connection for security
485+ (Black) 485- (White)	RS485 communication line	For digital communication control (PLC, IoT)
10V (blue), GND (gray)	0-10V speed control signal line	For analog speed control (0-10V controller)
VSP ( purple )	Backup 24V power cord	Some controllers have backup power lines

# 1. Local basic start-stop control

## 1.1 Breaker control



**Features:** Direct on/off control with fan operating at full speed, non-adjustable fan speed

**Wiring:** Connect the fan's three live wires (A, B, C) and the neutral wire (PE), without signal wires.

**Number of fans:** You can connect one fan per unit or one row of fans per unit (considering total Amps load)

**Wiring diagram:**

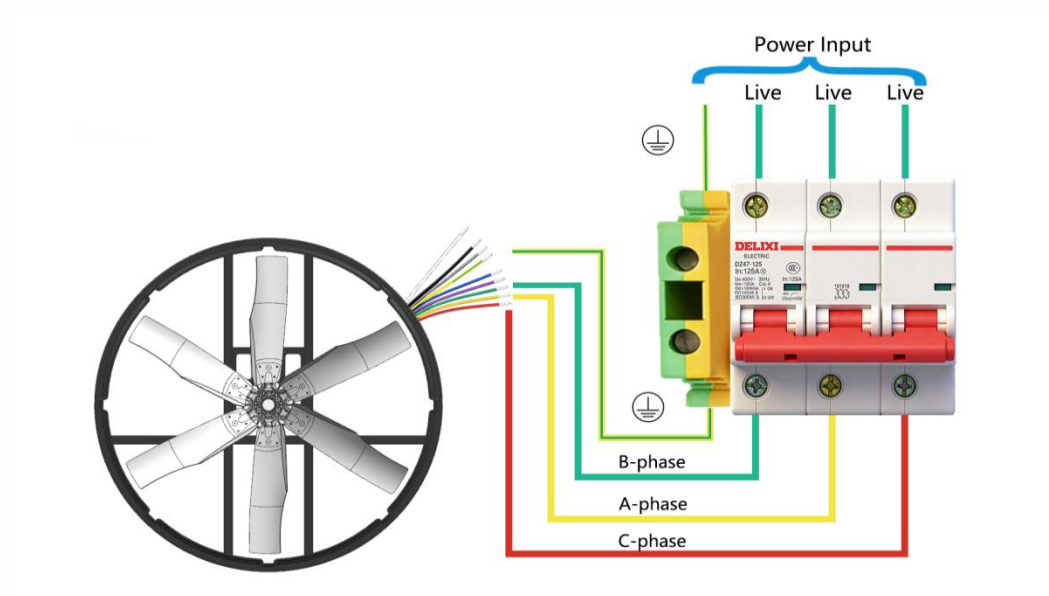

## 2. Local precise control

### 2.1 Local display panel manual knob control



**Features:** Manually adjust the fan speed using the knob, and view real-time data such as current, power, and fan speed on the display panel.

**Wiring:** Connect fan A, B, and C to the three-phase power supply. The RS485+ and RS485-signal lines require a 24V power supply cable (the driver's built-in VSP cable can be used directly).

**Number of fans:** 1 fan per unit

**Wiring diagram:**

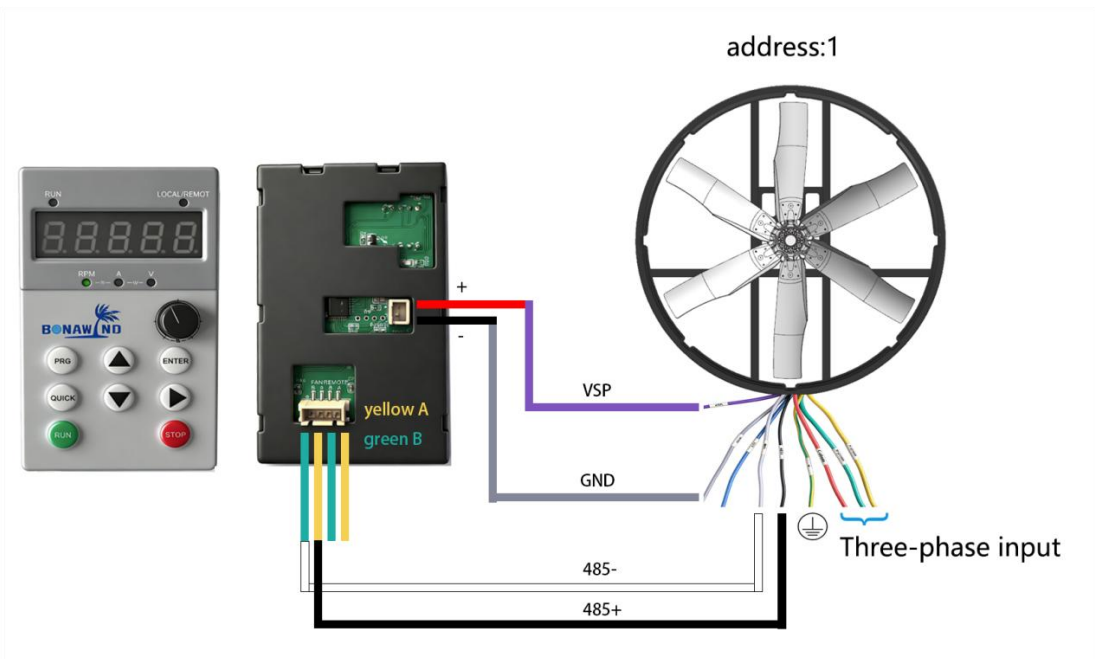

## 2.2 Local Simple Manual Knob Control



**Features:** The fan speed can be manually adjusted via a knob (0.8V = on, 10V = full speed).

**Wiring:** Fan A, B, C. The PE terminal connects to the breaker, while the 0-10V analog signal terminal (GHD) and 10V terminal are wired to the knob with an integrated breaker for power supply.

**Number of fans:** up to 10 fans

**Wiring diagram:**

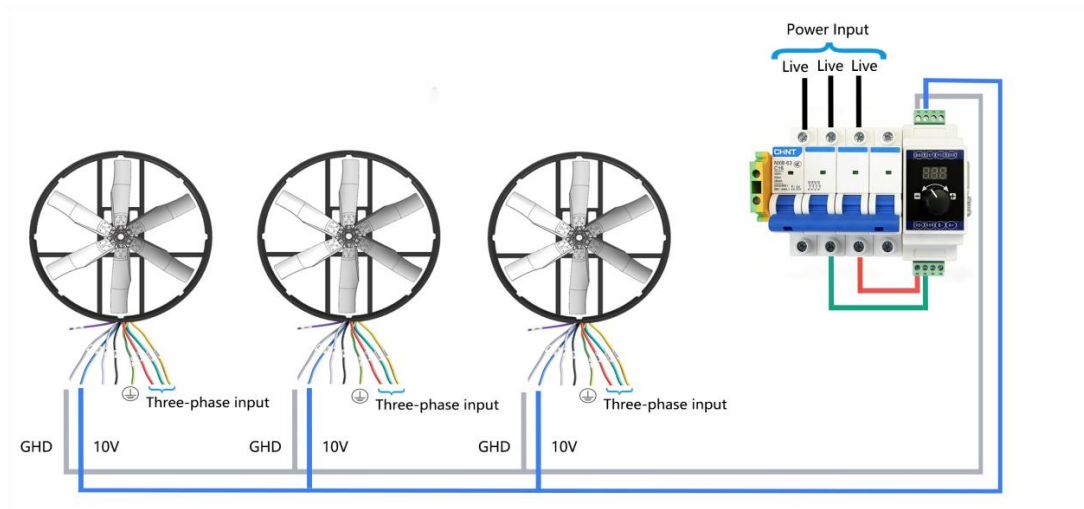

### 2.3 Local PLC Touch Screen Automatic Control



**Features:** The PLC is equipped with a built-in temperature sensor, allowing users to configure on-screen strategies for automatic fan speed adjustment based on temperature settings.

**Wiring:** Connect the fan power cable and RS485+/RS485-signal cables. The display screen requires a separate 220V single-phase power supply.

**Number of fans:** Up to 10 fans can be connected (set the address of one fan to 2)

**Wiring diagram:**

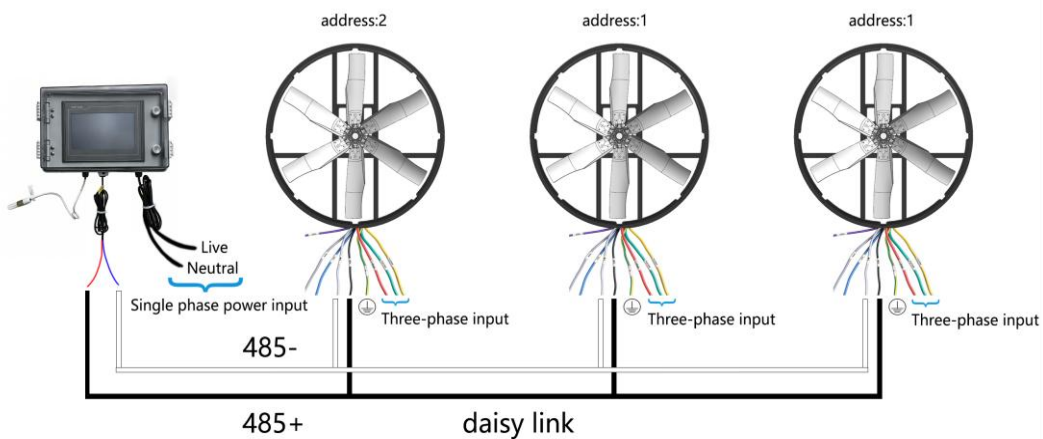

### 3. Remote Precision Strategy Automatic Control

#### 3.1 Intelligent Touch Screen with Remote Moonet APP Control



**Features:** Each fan drive is equipped with a LoRa module for wireless connectivity to the smart touchscreen, or can be connected via RS485+/RS485-signal lines. The smart touchscreen allows configuration of operational strategies, and the built-in temperature and humidity sensors enable automatic fan speed adjustment based on predefined parameters.

The smart touchscreen can also connect to the internet via Ethernet or WIFI, allowing remote control through the Moonet mobile APP.

**Wiring:** Use either LoRa wireless (requiring a 24V power supply, which can be directly provided via the VSP driver's reserved power cable) or RS485+/RS485-signal lines. The display must be connected to a separate 220V single-phase power supply.

**Number of fans:** Up to 32 fans can be connected (each fan requires a unique address, e.g., 2, 3, 4...)

**Wiring diagram:**

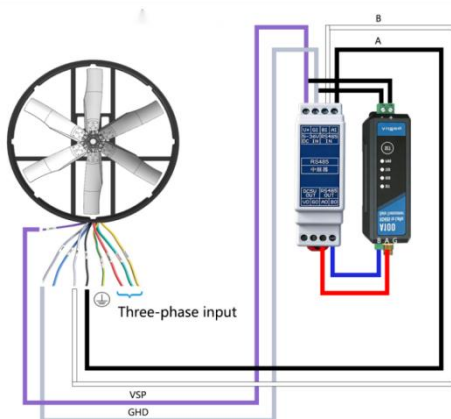

### 3.2 Remote Cloud Control: Gateway for Moonet APP control



**Features:** Each fan drive connects to the gateway via RS485+/RS485-daisy communication. The gateway establishes network connectivity through Ethernet cables or WIFI, enabling remote control via the Moonet mobile APP. The app allows configuration of policy-based temperature sensor integration, allowing fans to operate automatically according to predefined strategies.

**Wiring:** RS485+ and RS485-signal lines. The gateway requires a 24V power supply. The built-in control box includes a single-phase 220V to 24V power adapter.

**Number of fans:** Up to 10 fans can be connected (each fan requires a unique address, e.g., 2, 3, 4...)

**Wiring diagram:**

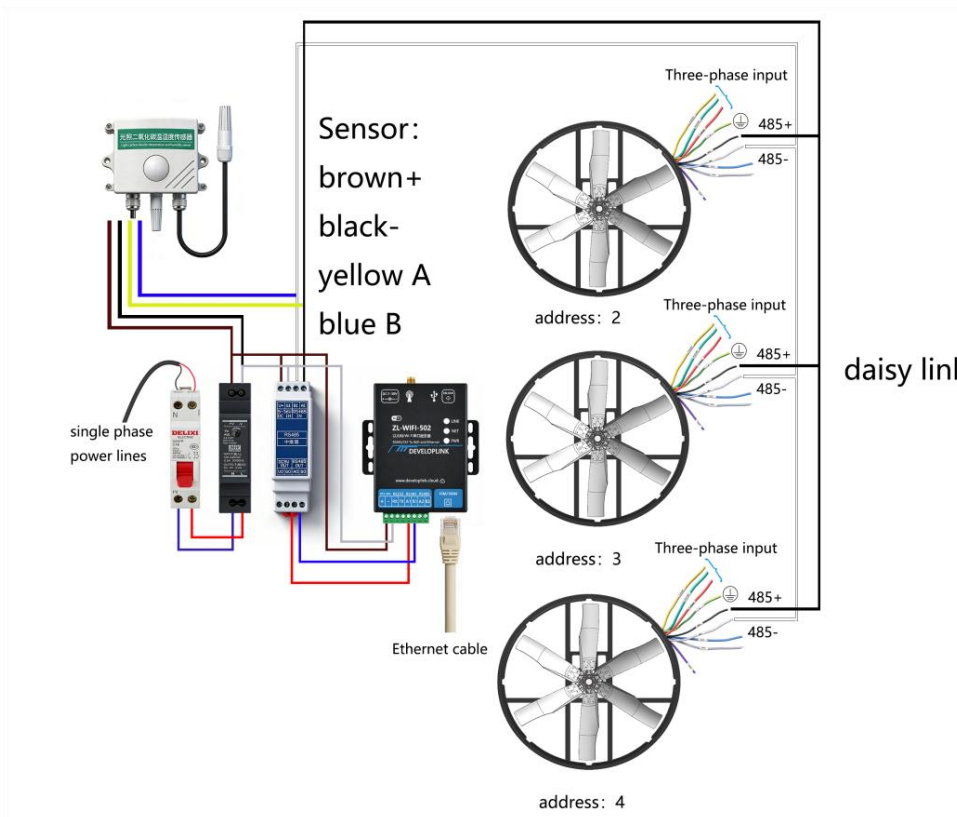

## Quality assurance policy

### Product warranty certificate (three guarantees of certificate)

Dear users, thank you for choosing Terrui series products! Shanghai Terrui provides three guarantees and quality assurance for its products.

1. The user shall immediately confirm the outer package and product quantity on the day of receipt of the damaged, please negotiate to the carrier on the spot and notify Shanghai Terrui; the user shall conduct a comprehensive acceptance of the product type, specification, appearance quality within 5 working days after receiving the goods, and mail or fax the certificate to Shanghai Terrui.
2. Under normal operation conditions, if the product has quality problems and without self-repair, the user will enjoy free warranty (including) within 12 months from the date of receiving the goods.
3. Terrui's quality policy: actively listen to customer needs; carefully build product quality; sincerely provide satisfactory service; always remember that customer service is the only reason for our existence.
4. After the warranty expires, Shanghai Terrui or authorized distributor will continue to provide paid after-sales service.
5. The right of interpretation of this clause is owned by Shanghai Terrui.
6. Please read this manual carefully.
7. Due to incorrect installation or disassembly, or in a bad, beyond the product suitable environment or overload operation.
8. The manufacturer will not be responsible for the damage caused by the above circumstances.
9. If there is any product problem during the product use, please stop using it immediately and contact with us for after-sales service consultation.
10. The product specifications are subject to change without notice.